



**PRODUCT SPECIFICATIONS**

Bulletin No. 210610

March 2015

Supersedes November 2014



**Nominal Capacity - 1.5 to 5 Tons**  
**Optional Electric Heat - 2.5 to 20 kW**

**MODEL NUMBER IDENTIFICATION**

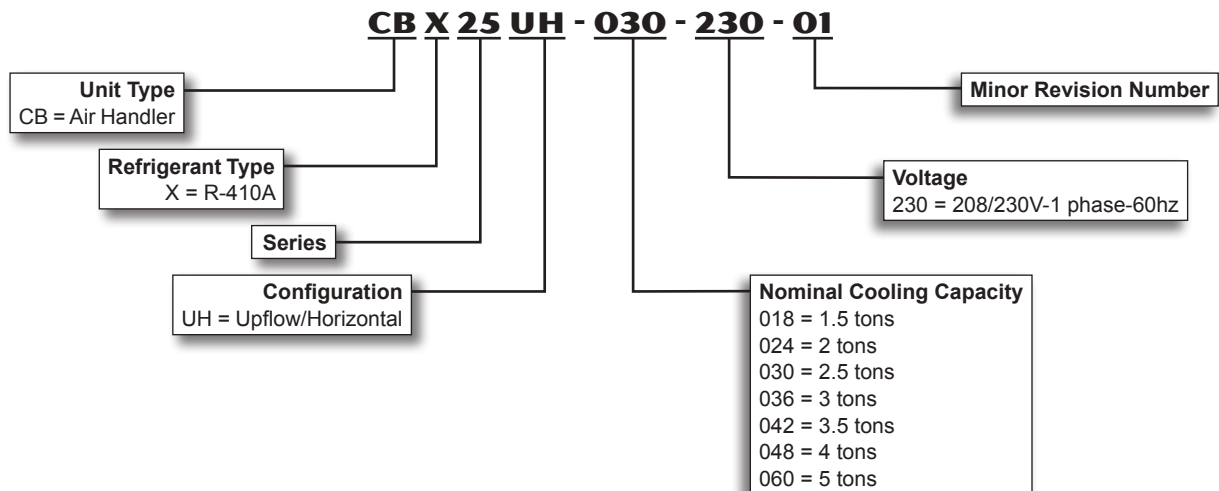

## FEATURES

### CONTENTS

Blower Data .....	6
Dimensions - Accessories.....	15
Dimensions - Unit .....	13
Electrical Data.....	5
Electric Heat Data.....	8
Features.....	2
Installation Clearances With Electric Heat.....	4
Model Number Identification .....	1
Optional Accessories .....	5
Specifications.....	5

### WARRANTY

**All covered components** - Limited five years in residential applications, one year in non-residential applications.

Refer to Lennox Limited Warranty Certificate included with each unit for additional details.

### APPLICATIONS

1.5 to 5 ton nominal sizes.

Upflow or horizontal applications. Downflow applications with optional conversion kit.

CBX25UH models are applicable to R-410A expansion valve systems in cooling applications and check and expansion valve systems in heat pump applications.

See bulletins in section Air Conditioners for cooling capacities.

See bulletins in section Heat Pump Outdoor Units for cooling and heating capacities.

Optional field installed electric heaters available in several sizes for additive heating capacity.

### APPROVALS

Tested with matching air conditioners and heat pump units in the Lennox Research Laboratory environmental test room in accordance with AHRI Standard 210/240.

Optional electric heaters are rated in accordance with US Department of Energy (DOE) test procedures and Federal Trade Commission (FTC) labeling regulations.

Air handlers and components within are bonded for grounding to meet safety standards for servicing required by ETL, NEC and CEC.

Units are ETL certified for the U.S. and Canada.

ISO 9001 Registered Manufacturing Quality System.

### REFRIGERANT SYSTEM

#### 1 Refrigerant Line Connections

Suction (vapor) and liquid lines have sweat connections that extended outside of the cabinet for ease of connection.

See dimension drawing for locations.

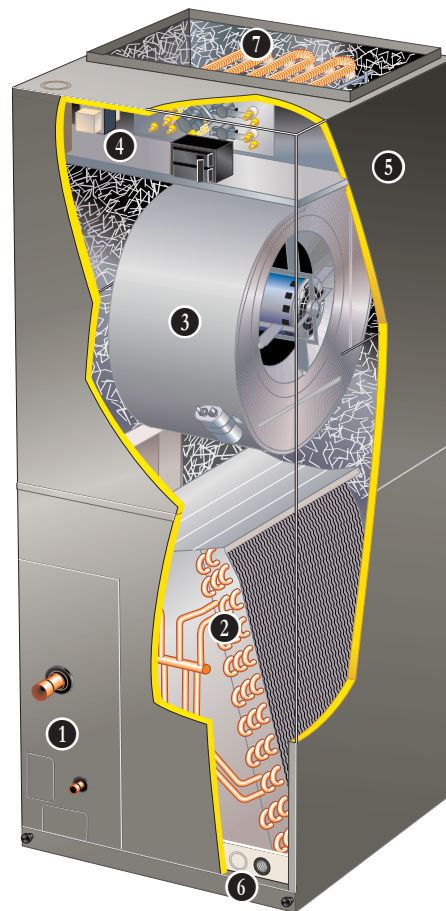

#### Check and Expansion Valve Furnished

CBX25UH models have non-chlorine, ozone friendly, R-410A valve.

Wide range valve.

Chatleff style fitting.

Factory installed on all models internal to cabinet.



#### 2 Copper Tube/Enhanced Fin Evaporator Coil

Assembled in "A" configuration.

Provides extra large surface and contact area, excellent heat transfer and low air resistance for maximum efficiency.

Precise circuiting for uniform refrigerant distribution.

Precisely spaced ripple-edged aluminum fins fitted to durable seamless copper tubes.

Fins are strengthened to resist bending and are equipped with collars that grip tubing for maximum contact area.

Lanced fins provide maximum exposure of fin surface to air stream.

Long life copper tubing is easy to service.

Rifled tubing provides superior heat transfer.

Flared shoulder tubing joints and silver soldering provide tight, leakproof joints.

Coil thoroughly factory tested under high pressure to ensure leakproof construction.

## FEATURES

### **FILTER**

- Disposable 1 inch filter is furnished.
- Filter rack furnished in cabinet for easy filter installation.
- See Specifications tables for filter sizes.

### **3 BLOWER**

- Multi-speed PSC motor.
- Choice of blower speeds. See blower performance tables.
- Speed changes easily accomplished by a simple wiring change.
- Blower is easily removed from unit for servicing.

#### **Time Delay Blower Relay**

Relay allows 30 second blower “on” delay before continuous fan or cooling operation and 45 second blower “off” delay after continuous fan or cooling operation.

### **CONTROLS**

#### **4 Transformer and Blower Cooling Relay**

- 24 volt transformer and blower cooling relay furnished as standard.
- Factory installed in the unit control box.

#### **Optional Accessories**

##### **Thermostat**

See Thermostat bulletins in Controls section and Lennox Price Book for a complete list of thermostats.

### **5 CABINET**

- Constructed of heavy gauge galvanized steel.
- Pre-painted cabinet finish.
- Completely insulated with foil faced fiberglass insulation.
- Removable panels provide complete service access.
- Filter access door for easy filter replacement.
- Thumbscrews hold filter door in place.
- Electrical inlets provided in sides and top of cabinet.
- See dimension drawing for locations.
- Knock-outs in cabinet for drain connections for upflow (left and right) and horizontal applications. See dimension drawing.

#### **Low Leakage Cabinet**

All models have less than 2% air leakage and meet ANSI/ASHRAE Standard 193-2010 “*Method of Test for Determining the Air Tightness of HVAC Equipment.*”

#### **Upflow/Horizontal Capability (Optional Downflow)**

- Shipped for upflow and horizontal left-hand discharge.
- May be field converted to horizontal right-hand air discharge by repositioning horizontal drain pan.
- Optional Downflow Conversion Kit available for field conversion.

### **6 Anti-Microbial Dual Position Drain Pans**

Anti-Microbial additive resists growth of mold and mildew on drain pan which improves indoor air quality and reduces drain line blockage.



Factory installed drain pans designed for upflow or horizontal applications.

Deep, corrosion resistant high temperature engineered polymer drain pans have dual pipe drains.

See dimension drawing.

#### **Optional Accessories**

##### **Downflow Conversion Kit**

Required for field conversion to downflow position. Kit consists of insulated downflow drain pan, insulated drain pan drip shields, coil drip shields, seal plates and support brackets for repositioning coil and drain pan. See Specifications table.

##### **Horizontal Support Frame Kit**

Provides support of unit in horizontal applications. Consists of (2) 1 x 1-1/2 x 32-5/8 in. and (2) 1 x 3 x 53-7/8 in. painted heavy gauge cold rolled steel support channels with assembly and suspending holes. Bolts and nuts furnished for field assembly. Suspending rods must be field provided.

##### **Side Return Unit Stand (Upflow Only)**

Raises unit 16 in. above floor for side return air duct connection.

Eliminates need for wooden platform construction.

All aluminum construction.

Two adjustable frames fit all sizes.

See Dimension Drawing.

##### **Wall Hanging Bracket Kit (Upflow Only)**

Allows unit to be hung on wall at any height.

Consists of heavy gauge steel support brackets (one for air handler unit, one for wall mount).

Screws furnished for fastening one bracket to unit.

Bolts for fastening one bracket to wall are field provided.

## FEATURES

### ELECTRICAL

#### Optional Accessories

#### 7 Electric Heat

Field install internal to unit cabinet.

Available in several kW sizes.

See Electric Heat tables.

Helix wound nichrome heating elements exposed directly in air stream resulting in instant heat transfer, low element temperatures and long service life.

Each element equipped with accurately located limit control with fixed temperature off setting and automatic reset.

Thermal sequencer relay brings elements on and off line, in sequence and equal increments, with time delay between each.

Initiates and terminates blower operation.

Heating control relay(s) furnished as standard.

Factory assembled with controls installed and wired.

Electric heat control wiring plugs into mating connector on air handler unit.



#### Circuit Breaker Models

ECB25-5CB, ECB25-7.5CB, ECB25-10CB, ECB25-12.5, ECB25-15CB, ECB25-20CB heaters are equipped with circuit breakers for overload and short circuit protection.

Factory wired and mounted on electric heat unit.

Current sensitive and temperature actuated.

Manual reset.

Flexible plastic circuit breaker cover protects circuit breaker in areas with high humidity or unconditioned areas to prevent nuisance tripping.

Circuit breakers qualify as disconnect means at unit in many areas, eliminate the need for field provided disconnect.

Consult local electrical code in your area.

#### Circuit Breaker Cover Kit

Flexible plastic cover protects circuit breaker.

Recommended in areas with high humidity or unconditioned areas to prevent nuisance tripping.

#### Single-Point Power Source Control Box

Control Box may be used with optional electric heat when single power supply is connected to multi-circuit electric heat.

Field installs external to the unit cabinet on either side or top.

Constructed of heavy gauge steel, baked enamel finish, prepunched mounting holes, electrical inlet knockouts, and terminal strip.

Removeable cover provides easy access.

Dimensions (H x W x D) - 7 x 7 x 4 in.

### INSTALLATION CLEARANCES WITH ELECTRIC HEAT

Cabinet	0 inch (0 mm)
To Plenum	0 inch (0 mm)
To Outlet Duct within 3 feet (914 mm)	0 inch (0 mm)
Floor	0 inch (0 mm) See Note #1
Service / Maintenance	See Note #2

<sup>1</sup> Units installed on combustible floors in the downflow position with electric heat do not require a downflow combustible flooring base.

<sup>2</sup> Front service access - 24 inches (610 mm) minimum.

NOTE - If cabinet depth is more than 24 inches (610 mm), allow a minimum of the cabinet depth plus 2 inches (51 mm).

### REPLACEMENT CIRCUIT BREAKERS

Voltage	Description	Catalog No.
208/240V - 1 Phase	25 amp, 2 pole	<b>41K13</b>
	30 amp, 2 pole	<b>17K70</b>
	35 amp, 2 pole	<b>72K07</b>
	40 amp, 2 pole	<b>49K14</b>
	45 amp, 2 pole	<b>17K71</b>
	50 amp, 2 pole	<b>41K12</b>
	60 amp, 2 pole	<b>17K72</b>

## SPECIFICATIONS

General Data		Model Number	CBX25UH-018	CBX25UH-024	CBX25UH-030	CBX25UH-036
		Nominal tonnage	1.5	2	2.5	3
Connections	Suction/Vapor line (o.d.) - in. sweat		3/4	3/4	3/4	7/8
	Liquid line (o.d.) - in. sweat		3/8	3/8	3/8	3/8
	Condensate - in. fpt		(2) 3/4	(2) 3/4	(2) 3/4	(2) 3/4
Indoor Coil	Net face area - ft. <sup>2</sup>		3.11	3.56	4.00	4.89
	Tube outside diameter - in.		3/8	3/8	3/8	3/8
	Number of rows		3	3	3	3
	Fins per inch		14	14	14	14
Blower	Wheel nominal diameter x width - in.		9 x 6	9 x 6	10 x 8	9 x 10
	Blower motor output - hp		1/5	1/3	1/3	1/2
<sup>1</sup> Filters	Size of filter - in.		12 x 20 x 1	15 x 20 x 1	15 x 20 x 1	18 x 20 x 1
Shipping Data -1 package - lbs.			105	123	126	161

## ELECTRICAL DATA

Voltage - 1 phase (60 hz)		208/240V	208/240V	208/240V	208/240V
<sup>2</sup> Maximum overcurrent protection (unit only)		15	15	15	15
<sup>3</sup> Minimum circuit ampacity (unit only)		1.4	2.0	2.4	2.9
Blower Motor Full Load Amps		1.1	1.6	1.9	2.3

## SPECIFICATIONS

General Data		Model Number	CBX25UH-042	CBX25UH-048	CBX25UH-060
		Nominal tonnage	3.5	4	5
Connections	Suction/Vapor line (o.d.) - in. sweat		7/8	7/8	7/8
	Liquid line (o.d.) - in. sweat		3/8	3/8	3/8
	Condensate - in. fpt		(2) 3/4	(2) 3/4	(2) 3/4
Indoor Coil	Net face area - ft. <sup>2</sup>		5.83	7.00	7.00
	Tube outside diameter - in.		3/8	3/8	3/8
	Number of rows		3	3	3
	Fins per inch		14	14	14
Blower	Wheel nominal diameter x width - in.		12 x 8	11 x 9	12 x 9
	Blower motor output - hp		1/3	1/2	1/2
<sup>1</sup> Filters	Size of filter - in.		18 x 24 x 1	18 x 24 x 1	18 x 24 x 1
Shipping Data -1 package - lbs.			163	186	186

## ELECTRICAL DATA

Voltage - 1 phase (60 hz)		208/240V	208/240V	208/240V
<sup>2</sup> Maximum overcurrent protection (unit only)		15	15	15
<sup>3</sup> Minimum circuit ampacity (unit only)		2.4	4.9	4.9
Blower Motor Full Load Amps		1.9	3.9	3.9

<sup>1</sup> Disposable filter.

<sup>2</sup> HACR type circuit breaker or fuse.

<sup>3</sup> Refer to National or Canadian Electrical Code manual to determine wire, fuse and disconnect size requirements. Use wires suitable for at least 167°F.

## OPTIONAL ACCESSORIES - ORDER SEPARATELY

Model	-018	-024 -030	-036	-042 -048 -060
Downflow Conversion Kit	96W37	96W38	97W95	97W96
Horizontal Support Frame Kit	56J18	56J18	56J18	56J18
Side Return Unit Stand (Upflow Only)	45K31	45K32	45K32	45K32
Single-Point Power Source Control Box (for Electric Heat)	21H39	21H39	21H39	21H39
Wall Hanging Bracket Kit (Upflow Only)	45K30	45K30	45K30	45K30

## BLOWER DATA - UPFLOW AND HORIZONTAL

### CBX25UH-018 BLOWER PERFORMANCE

External Static Pressure in. w.g.	Air Volume at Specific Blower Taps (cfm)		
	High	Medium	Low
0.10	905	670	510
0.20	865	650	495
0.30	820	630	475
0.40	770	595	415
0.50	700	500	325

NOTE - All air data measured external to unit with dry coil and 1 inch non-pleated air filter in place.  
Electric heaters have no appreciable air resistance.

### CBX25UH-042 BLOWER PERFORMANCE

External Static Pressure in. w.g.	Air Volume at Specific Blower Taps (cfm)		
	High	Medium	Low
0.10	1820	1490	1325
0.20	1770	1465	1315
0.30	1690	1440	1300
0.40	1600	1395	1275
0.50	1500	1315	1225

NOTE - All air data measured external to unit with dry coil and 1 inch non-pleated air filter in place.  
Electric heaters have no appreciable air resistance.

### CBX25UH-024 BLOWER PERFORMANCE

External Static Pressure in. w.g.	Air Volume at Specific Blower Taps (cfm)		
	High	Medium	Low
0.10	1130	885	630
0.20	1100	875	625
0.30	1070	850	615
0.40	1010	820	610
0.50	950	780	580

NOTE - All air data measured external to unit with dry coil and 1 inch non-pleated air filter in place.  
Electric heaters have no appreciable air resistance.

### CBX25UH-048 BLOWER PERFORMANCE

External Static Pressure in. w.g.	Air Volume at Specific Blower Taps (cfm)		
	High	Medium	Low
0.10	2070	1995	1775
0.20	1970	1895	1710
0.30	1850	1800	1645
0.40	1720	1685	1565
0.50	1595	1560	1470

NOTE - All air data measured external to unit with dry coil and 1 inch non-pleated air filter in place.  
Electric heaters have no appreciable air resistance.

### CBX25UH-030 BLOWER PERFORMANCE

External Static Pressure in. w.g.	Air Volume at Specific Blower Taps (cfm)		
	High	Medium	Low
0.10	1240	1075	900
0.20	1210	1060	865
0.30	1170	1030	830
0.40	1135	985	785
0.50	1085	940	740

NOTE - All air data measured external to unit with dry coil and 1 inch non-pleated air filter in place.  
Electric heaters have no appreciable air resistance.

### CBX25UH-060 BLOWER PERFORMANCE

External Static Pressure in. w.g.	Air Volume at Specific Blower Taps (cfm)		
	High	Medium	Low
0.10	2140	1965	1675
0.20	2085	1925	1630
0.30	2000	1875	1580
0.40	1895	1800	1520
0.50	1795	1695	1450

NOTE - All air data measured external to unit with dry coil and 1 inch non-pleated air filter in place.  
Electric heaters have no appreciable air resistance.

### CBX25UH-036 BLOWER PERFORMANCE

External Static Pressure in. w.g.	Air Volume at Specific Blower Taps (cfm)		
	High	Medium	Low
0.10	1660	1500	1160
0.20	1575	1445	1140
0.30	1495	1385	1115
0.40	1405	1300	1085
0.50	1390	1200	990

NOTE - All air data measured external to unit with dry coil and 1 inch non-pleated air filter in place.  
Electric heaters have no appreciable air resistance.

## BLOWER DATA - DOWNFLOW

### CBX25UH-018 BLOWER PERFORMANCE

External Static Pressure in. w.g.	Air Volume at Specific Blower Taps (cfm)		
	High	Medium	Low
0.10	670	600	495
0.20	630	565	460
0.30	590	500	420
0.40	515	465	380
0.50	470	410	330

NOTE - All air data measured external to unit with dry coil and 1 inch non-pleated air filter in place.  
Electric heaters have no appreciable air resistance.

### CBX25UH-024 BLOWER PERFORMANCE

External Static Pressure in. w.g.	Air Volume at Specific Blower Taps (cfm)		
	High	Medium	Low
0.10	945	840	630
0.20	890	800	615
0.30	850	760	595
0.40	795	705	560
0.50	730	605	465

NOTE - All air data measured external to unit with dry coil and 1 inch non-pleated air filter in place.  
Electric heaters have no appreciable air resistance.

### CBX25UH-030 BLOWER PERFORMANCE

External Static Pressure in. w.g.	Air Volume at Specific Blower Taps (cfm)		
	High	Medium	Low
0.10	1105	950	820
0.20	1065	915	780
0.30	1010	870	745
0.40	960	825	695
0.50	900	660	615

NOTE - All air data measured external to unit with dry coil and 1 inch non-pleated air filter in place.  
Electric heaters have no appreciable air resistance.

### CBX25UH-036 BLOWER PERFORMANCE

External Static Pressure in. w.g.	Air Volume at Specific Blower Taps (cfm)		
	High	Medium	Low
0.10	1195	1160	1065
0.20	1090	1065	985
0.30	1020	990	935
0.40	960	925	865
0.50	885	850	805

NOTE - All air data measured external to unit with dry coil and 1 inch non-pleated air filter in place.  
Electric heaters have no appreciable air resistance.

### CBX25UH-042 BLOWER PERFORMANCE

External Static Pressure in. w.g.	Air Volume at Specific Blower Taps (cfm)		
	High	Medium	Low
0.10	1460	1375	1310
0.20	1375	1295	1245
0.30	1315	1235	1180
0.40	1225	1150	1120
0.50	1145	1055	1025

NOTE - All air data measured external to unit with dry coil and 1 inch non-pleated air filter in place.  
Electric heaters have no appreciable air resistance.

### CBX25UH-048 BLOWER PERFORMANCE

External Static Pressure in. w.g.	Air Volume at Specific Blower Taps (cfm)		
	High	Medium	Low
0.10	1725	1665	1605
0.20	1640	1585	1520
0.30	1550	1495	1435
0.40	1455	1400	1350
0.50	1350	1280	1105

NOTE - All air data measured external to unit with dry coil and 1 inch non-pleated air filter in place.  
Electric heaters have no appreciable air resistance.

### CBX25UH-060 BLOWER PERFORMANCE

External Static Pressure in. w.g.	Air Volume at Specific Blower Taps (cfm)		
	High	Medium	Low
0.10	1785	1730	1630
0.20	1700	1650	1555
0.30	1605	1570	1490
0.40	1505	1455	1390
0.50	1390	1370	1280

NOTE - All air data measured external to unit with dry coil and 1 inch non-pleated air filter in place.  
Electric heaters have no appreciable air resistance.

## ELECTRIC HEAT DATA

SINGLE PHASE		CBX25UH-018					
Description	Input			Blower Motor Full Load Amps	<sup>2</sup> Minimum Circuit Ampacity	<sup>3</sup> Maximum Overcurrent Protection	
	Volt	kW	<sup>1</sup> Btuh				
<b>2.5 kW</b> ECB25-2.5 (12R08) Wire Leads	208	1.9	6,400	1.1	13	15	
	220	2.1	7,200	1.1	13	15	
	230	2.3	7,800	1.1	14	15	
	240	2.5	8,500	1.1	14	15	
<b>5 kW</b> ECB25-5 (12R45) Terminal Block ECB25-5CB (12R60) 30A Circuit Breaker	208	3.8	12,800	1.1	24	<sup>4</sup> 25	
	220	4.2	14,300	1.1	25	<sup>4</sup> 25	
	230	4.6	15,700	1.1	26	30	
	240	5.0	17,100	1.1	27	30	
<b>7.5 kW</b> ECB25-7.5 (12R61) Terminal Block ECB25-7.5CB (12S08) 45A Circuit Breaker	208	5.6	19,200	1.1	35	<sup>4</sup> 40	
	220	6.3	21,500	1.1	37	<sup>4</sup> 40	
	230	6.9	23,500	1.1	39	<sup>4</sup> 40	
	240	7.5	25,600	1.1	40	<b>45</b>	
<b>10 kW</b> ECB25-10 (10Z43) Terminal Block ECB25-10CB (10T37) 60A Circuit Breaker	208	6.8	23,000	1.1	42	<sup>4</sup> 45	
	220	7.6	25,800	1.1	44	<sup>4</sup> 45	
	230	8.3	28,200	1.1	46	<sup>4</sup> 50	
	240	9.0	30,700	1.1	48	<sup>4</sup> 50	
SINGLE PHASE		CBX25UH-024					
Description	Input			Blower Motor Full Load Amps	<sup>2</sup> Minimum Circuit Ampacity	<sup>3</sup> Maximum Overcurrent Protection	
	Volt	kW	<sup>1</sup> Btuh				
<b>2.5 kW</b> ECB25-2.5 (12R08) Wire Leads	208	1.9	6,400	1.6	13	15	
	220	2.1	7,200	1.6	14	15	
	230	2.3	7,800	1.6	15	15	
	240	2.5	8,500	1.6	15	15	
<b>5 kW</b> ECB25-5 (12R45) Terminal Block ECB25-5CB (12R60) 30A Circuit Breaker	208	3.8	12,800	1.6	25	<sup>4</sup> 25	
	220	4.2	14,300	1.6	26	30	
	230	4.6	15,700	1.6	27	30	
	240	5.0	17,100	1.6	28	30	
<b>7.5 kW</b> ECB25-7.5 (12R61) Terminal Block ECB25-7.5CB (12S08) 45A Circuit Breaker	208	5.6	19,200	1.6	36	<sup>4</sup> 40	
	220	6.3	21,500	1.6	38	<sup>4</sup> 40	
	230	6.9	23,500	1.6	40	<sup>4</sup> 40	
	240	7.5	25,600	1.6	41	45	
<b>10 kW</b> ECB25-10 (10Z43) Terminal Block ECB25-10CB (10T37) 60A Circuit Breaker	208	6.8	23,000	1.6	43	<sup>4</sup> 45	
	220	7.6	25,800	1.6	45	<sup>4</sup> 45	
	230	8.3	28,200	1.6	47	<sup>4</sup> 50	
	240	9.0	30,700	1.6	49	<sup>4</sup> 50	

NOTE - Circuit 1 Minimum Circuit Ampacity includes the Blower Motor Full Load Amps.

<sup>1</sup> Electric heater capacity only - does not include additional blower motor heat capacity.

<sup>2</sup> Refer to National or Canadian Electrical Code manual to determine wire, fuse and disconnect size requirements. Use wires suitable for at least 167°F.

<sup>3</sup> HACR type breaker or fuse.

<sup>4</sup> **Bold indicates that the circuit breaker on "CB" circuit breaker models must be replaced with size shown. See table on page 4.**

## ELECTRIC HEAT DATA

SINGLE PHASE		CBX25UH-030									
Description	Input			Blower Motor Full Load Amps	<sup>2</sup> Minimum Circuit Ampacity		<sup>3</sup> Maximum Overcurrent Protection		Single Point Power Source		
	Volt	kW	<sup>1</sup> Btuh		Ckt 1	Ckt 2	Ckt 1	Ckt 2	<sup>2</sup> Minimum Circuit Ampacity	<sup>3</sup> Maximum Overcurrent Protection	
<b>2.5 kW</b> ECB25-2.5 (12R08) Wire Leads	208	1.9	6,400	1.9	14	---	15	---	---	---	
	220	2.1	7,200	1.9	14	---	15	---	---	---	
	230	2.3	7,800	1.9	15	---	15	---	---	---	
	240	2.5	8,500	1.9	15	---	15	---	---	---	
<b>5 kW</b> ECB25-5 (12R45) Terminal Block ECB25-5CB (12R60) 30A Circuit Breaker	208	3.8	12,800	1.9	25	---	<sup>4</sup> 25	---	---	---	
	220	4.2	14,300	1.9	26	---	30	---	---	---	
	230	4.6	15,700	1.9	27	---	30	---	---	---	
	240	5.0	17,100	1.9	28	---	30	---	---	---	
<b>7.5 kW</b> ECB25-7.5 (12R61) Terminal Block ECB25-7.5CB (12S08) 45A Circuit Breaker	208	5.6	19,200	1.9	36	---	<sup>4</sup> 40	---	---	---	
	220	6.3	21,500	1.9	38	---	<sup>4</sup> 40	---	---	---	
	230	6.9	23,500	1.9	40	---	<sup>4</sup> 40	---	---	---	
	240	7.5	25,600	1.9	41	---	45	---	---	---	
<b>10 kW</b> ECB25-10 (10Z43) Terminal Block ECB25-10CB (10T37) 60A Circuit Breaker	208	6.8	23,000	1.9	43	---	<sup>4</sup> 45	---	---	---	
	220	7.6	25,800	1.9	45	---	<sup>4</sup> 45	---	---	---	
	230	8.3	28,200	1.9	47	---	<sup>4</sup> 50	---	---	---	
	240	9.0	30,700	1.9	49	---	<sup>4</sup> 50	---	---	---	
<b>12.5 kW</b> ECB25-12.5CB (12S77) (1) 50A and (1) 25A Circuit Breaker	208	9.4	32,000	1.9	40	19	<sup>4</sup> 40	<sup>4</sup> 20	58	60	
	220	10.5	35,800	1.9	42	20	<sup>4</sup> 45	<sup>4</sup> 20	61	70	
	230	11.5	39,200	1.9	44	21	<sup>4</sup> 45	25	64	70	
	240	12.5	42,600	1.9	46	22	50	25	66	70	
<b>15 kW</b> ECB25-15CB (12S87) (1) 60A and (1) 30A Circuit Breaker	208	11.3	38,400	1.9	25	45	<sup>4</sup> 25	<sup>4</sup> 50	69	70	
	220	12.6	43,000	1.9	26	48	30	<sup>4</sup> 50	73	80	
	230	13.5	47,000	1.9	27	50	30	<sup>4</sup> 50	76	80	
	240	15.0	51,200	1.9	28	52	30	60	80	80	

NOTE - Circuit 1 Minimum Circuit Ampacity includes the Blower Motor Full Load Amps.

<sup>1</sup> Electric heater capacity only - does not include additional blower motor heat capacity.

<sup>2</sup> Refer to National or Canadian Electrical Code manual to determine wire, fuse and disconnect size requirements. Use wires suitable for at least 167°F.

<sup>3</sup> HACR type breaker or fuse.

<sup>4</sup> Bold indicates that the circuit breaker on "CB" circuit breaker models must be replaced with size shown. See table on page 4.

## ELECTRIC HEAT DATA

SINGLE PHASE		CBX25UH-036									
Description	Input			Blower Motor Full Load Amps	<sup>2</sup> Minimum Circuit Ampacity		<sup>3</sup> Maximum Overcurrent Protection		Single Point Power Source		
	Volt	kW	<sup>1</sup> Btuh		Ckt 1	Ckt 2	Ckt 1	Ckt 2	<sup>2</sup> Minimum Circuit Ampacity	<sup>3</sup> Maximum Overcurrent Protection	
<b>2.5 kW</b>	ECB25-2.5 (12R08) Wire Leads	208	1.9	6,400	2.3	14	---	15	---	---	---
		220	2.1	7,200	2.3	15	---	15	---	---	---
		230	2.3	7,800	2.3	15	---	15	---	---	---
		240	2.5	8,500	2.3	16	---	20	---	---	---
<b>5 kW</b>	ECB25-5 (12R45) Terminal Block ECB25-5CB (12S60) 30A Circuit Breaker	208	3.8	12,800	2.3	25	---	<b><sup>4</sup>25</b>	---	---	---
		220	4.2	14,300	2.3	27	---	30	---	---	---
		230	4.6	15,700	2.3	28	---	30	---	---	---
		240	5.0	17,100	2.3	29	---	30	---	---	---
<b>7.5 kW</b>	ECB25-7.5 (12R61) Terminal Block ECB25-7.5CB (12S08) 45A Circuit Breaker	208	5.6	19,200	2.3	37	---	<b><sup>4</sup>40</b>	---	---	---
		220	6.3	21,500	2.3	39	---	<b><sup>4</sup>40</b>	---	---	---
		230	6.9	23,500	2.3	40	---	<b><sup>4</sup>40</b>	---	---	---
		240	7.5	25,600	2.3	42	---	45	---	---	---
<b>10 kW</b>	ECB25-10 (10Z43) Terminal Block ECB25-10CB (10T37) 60A Circuit Breaker	208	6.8	23,000	2.3	43	---	<b><sup>4</sup>45</b>	---	---	---
		220	7.6	25,800	2.3	46	---	<b><sup>4</sup>50</b>	---	---	---
		230	8.3	28,200	2.3	48	---	<b><sup>4</sup>50</b>	---	---	---
		240	9.0	30,700	2.3	50	---	<b><sup>4</sup>50</b>	---	---	---
<b>12.5 kW</b>	ECB25-12.5CB (12S77) (1) 50A and (1) 25A Circuit Breaker	208	9.4	32,000	2.3	40	19	<b><sup>4</sup>40</b>	<b><sup>4</sup>20</b>	59	60
		220	10.5	35,800	2.3	43	20	<b><sup>4</sup>45</b>	<b><sup>4</sup>20</b>	62	70
		230	11.5	39,200	2.3	44	21	<b><sup>4</sup>45</b>	25	65	70
		240	12.5	42,600	2.3	46	22	50	25	68	70
<b>15 kW</b>	ECB25-15CB (12S87) (1) 60A and (1) 30A Circuit Breaker	208	11.3	38,400	2.3	25	45	<b><sup>4</sup>25</b>	<b><sup>4</sup>50</b>	70	70
		220	12.6	43,000	2.3	27	48	30	<b><sup>4</sup>50</b>	74	80
		230	13.5	47,000	2.3	28	50	30	<b><sup>4</sup>50</b>	78	80
		240	15.0	51,200	2.3	29	52	30	60	81	90

NOTE - Circuit 1 Minimum Circuit Ampacity includes the Blower Motor Full Load Amps.

<sup>1</sup> Electric heater capacity only - does not include additional blower motor heat capacity.

<sup>2</sup> Refer to National or Canadian Electrical Code manual to determine wire, fuse and disconnect size requirements. Use wires suitable for at least 167°F.

<sup>3</sup> HACR type breaker or fuse.

<sup>4</sup> Bold indicates that the circuit breaker on "CB" circuit breaker models must be replaced with size shown. See table on page 4.

## ELECTRIC HEAT DATA

SINGLE PHASE		CBX25UH-042									
		Input			Blower Motor Full Load Amps	<sup>2</sup> Minimum Circuit Ampacity		<sup>3</sup> Maximum Overcurrent Protection		Single Point Power Source	
		Volt	kW	<sup>1</sup> Btuh		Ckt 1	Ckt 2	Ckt 1	Ckt 2	<sup>2</sup> Minimum Circuit Ampacity	<sup>3</sup> Maximum Overcurrent Protection
<b>2.5 kW</b>	ECB25-2.5 (12R08) Wire Leads	208	1.9	6,400	1.9	14	---	15	---	---	---
		220	2.1	7,200	1.9	14	---	15	---	---	---
		230	2.3	7,800	1.9	15	---	15	---	---	---
		240	2.5	8,500	1.9	15	---	15	---	---	---
<b>5 kW</b>	ECB25-5 (12R45) Terminal Block ECB25-5CB (12R60) 30A Circuit Breaker	208	3.8	12,800	1.9	25	---	<b><sup>4</sup>25</b>	---	---	---
		220	4.2	14,300	1.9	26	---	30	---	---	---
		230	4.6	15,700	1.9	27	---	30	---	---	---
		240	5.0	17,100	1.9	28	---	30	---	---	---
<b>7.5 kW</b>	ECB25-7.5 (12R61) Terminal Block ECB25-7.5CB (12S08) 45A Circuit Breaker	208	5.6	19,200	1.9	36	---	<b><sup>4</sup>40</b>	---	---	---
		220	6.3	21,500	1.9	38	---	<b><sup>4</sup>40</b>	---	---	---
		230	6.9	23,500	1.9	40	---	<b><sup>4</sup>40</b>	---	---	---
		240	7.5	25,600	1.9	41	---	45	---	---	---
<b>10 kW</b>	ECB25-10 (10Z43) Terminal Block ECB25-10CB (10T37) 60A Circuit Breaker	208	6.8	23,000	1.9	43	---	<b><sup>4</sup>45</b>	---	---	---
		220	7.6	25,800	1.9	45	---	<b><sup>4</sup>45</b>	---	---	---
		230	8.3	28,200	1.9	47	---	<b><sup>4</sup>50</b>	---	---	---
		240	9.0	30,700	1.9	49	---	<b><sup>4</sup>50</b>	---	---	---
<b>12.5 kW</b>	ECB25-12.5CB (12S77) (1) 50A and (1) 25A Circuit Breaker	208	9.4	32,000	1.9	40	19	<b><sup>4</sup>40</b>	<b><sup>4</sup>20</b>	54	60
		220	10.5	35,800	1.9	42	20	<b><sup>4</sup>45</b>	<b><sup>4</sup>20</b>	62	70
		230	11.5	39,200	1.9	44	21	<b><sup>4</sup>45</b>	25	65	70
		240	12.5	42,600	1.9	46	22	50	25	67	70
<b>15 kW</b>	ECB25-15CB (12S87) (1) 60A and (1) 30A Circuit Breaker	208	11.3	38,400	1.9	25	45	<b><sup>4</sup>25</b>	<b><sup>4</sup>50</b>	70	70
		220	12.6	43,000	1.9	26	48	30	<b><sup>4</sup>50</b>	74	80
		230	13.5	47,000	1.9	27	50	30	<b><sup>4</sup>50</b>	77	80
		240	15.0	51,200	1.9	28	52	30	60	81	90

NOTE - Circuit 1 Minimum Circuit Ampacity includes the Blower Motor Full Load Amps.

<sup>1</sup> Electric heater capacity only - does not include additional blower motor heat capacity.

<sup>2</sup> Refer to National or Canadian Electrical Code manual to determine wire, fuse and disconnect size requirements. Use wires suitable for at least 167°F.

<sup>3</sup> HACR type breaker or fuse.

<sup>4</sup> Bold indicates that the circuit breaker on "CB" circuit breaker models must be replaced with size shown. See table on page 4.

## ELECTRIC HEAT DATA

SINGLE PHASE		CBX25UH-048, CBX25UH-060									
Description	Input			Blower Motor Full Load Amps	<sup>2</sup> Minimum Circuit Ampacity		<sup>3</sup> Maximum Overcurrent Protection		Single Point Power Source		
	Volt	kW	<sup>1</sup> Btuh		Ckt 1	Ckt 2	Ckt 1	Ckt 2	<sup>2</sup> Minimum Circuit Ampacity	<sup>3</sup> Maximum Overcurrent Protection	
<b>5 kW</b>	ECB25-5 (12R45) Terminal Block ECB25-5CB (12R60) 30A Circuit Breaker	208	3.8	12,800	3.9	27	---	30	---	---	---
		220	4.2	14,300	3.9	29	---	30	---	---	---
		230	4.6	15,700	3.9	30	---	30	---	---	---
		240	5.0	17,100	3.9	31	---	<b>35</b>	---	---	---
<b>7.5 kW</b>	ECB25-7.5 (12R61) Terminal Block ECB25-7.5CB (12S08) 45A Circuit Breaker	208	5.6	19,200	3.9	39	---	<b>40</b>	---	---	---
		220	6.3	21,500	3.9	41	---	45	---	---	---
		230	6.9	23,500	3.9	42	---	45	---	---	---
		240	7.5	25,600	3.9	44	---	45	---	---	---
<b>10 kW</b>	ECB25-10 (10Z43) Terminal Block ECB25-10CB (10T37) 60A Circuit Breaker	208	6.8	23,000	3.9	45	---	<b>45</b>	---	---	---
		220	7.6	25,800	3.9	48	---	<b>50</b>	---	---	---
		230	8.3	28,200	3.9	50	---	<b>50</b>	---	---	---
		240	9.0	30,700	3.9	52	---	60	---	---	---
<b>12.5 kW</b>	ECB25-12.5CB (12S77) (1) 50A and (1) 25A Circuit Breaker	208	9.4	32,000	3.9	42	19	<b>45</b>	<b>20</b>	61	70
		220	10.5	35,800	3.9	45	20	<b>45</b>	<b>20</b>	64	70
		230	11.5	39,200	3.9	46	21	50	25	67	70
		240	12.5	42,600	3.9	48	22	50	25	70	70
<b>15 kW</b>	ECB25-15CB (12S87) (1) 60A and (1) 30A Circuit Breaker	208	11.3	38,400	3.9	27	45	30	<b>50</b>	72	80
		220	12.6	43,000	3.9	29	48	30	<b>50</b>	76	80
		230	13.5	47,000	3.9	30	50	30	<b>50</b>	80	80
		240	15.0	51,200	3.9	31	52	<b>35</b>	60	83	90
<b>20 kW</b>	ECB25-20CB (10T35) (1) 60A and (1) 60A Circuit Breaker	208	15.0	51,200	3.9	45	50	<b>45</b>	<b>50</b>	95	100
		220	16.8	57,300	3.9	48	53	<b>50</b>	60	100	100
		230	18.4	62,700	3.9	50	55	<b>50</b>	60	105	110
		240	20.0	68,200	3.9	52	57	60	60	109	110

NOTE - Circuit 1 Minimum Circuit Ampacity includes the Blower Motor Full Load Amps.

<sup>1</sup> Electric heater capacity only - does not include additional blower motor heat capacity.

<sup>2</sup> Refer to National or Canadian Electrical Code manual to determine wire, fuse and disconnect size requirements. Use wires suitable for at least 167°F.

<sup>3</sup> HACR type breaker or fuse.

<sup>4</sup> **Bold indicates that the circuit breaker on "CB" circuit breaker models must be replaced with size shown. See table on page 4.**

**DIMENSIONS - UNIT - UPFLOW - INCHES (MM)**

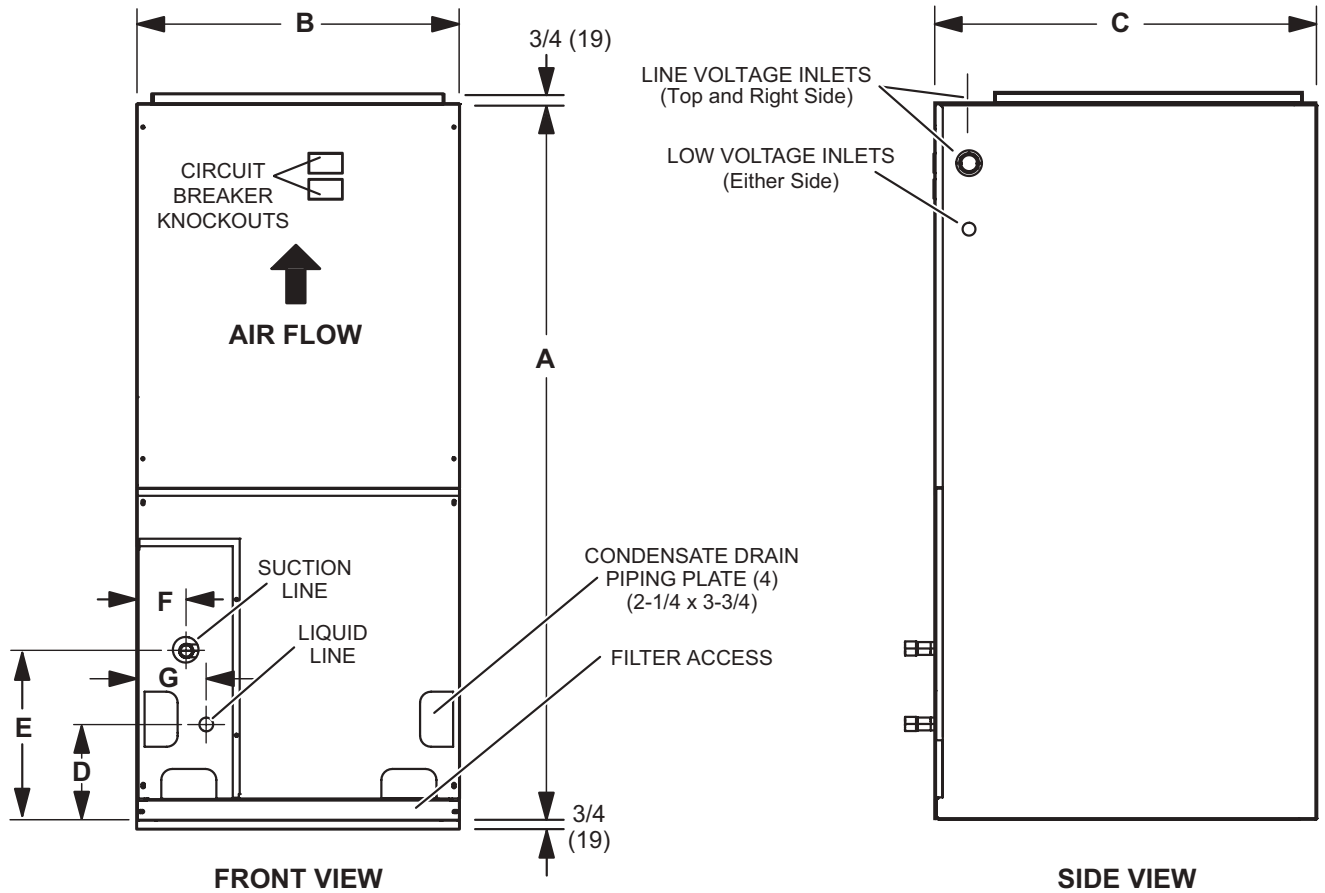

Dimension	018		024		030		036		042		048-060		
	in.	mm	in.	mm	in.	mm	in.	mm	in.	mm	in.	mm	
<b>A</b>	38	965	40-1/2	1029	43	1092	48	1219	48	1219	52-1/2	1334	
<b>B</b>	15	381	18-1/2	470	18-1/2	470	21-7/8	556	21-7/8	556	21-7/8	556	
<b>C</b>	22	559	22	559	22	559	22	559	26	660	26	660	
<b>D</b>	6	152	6	152	6	152	12-1/4	311	6-1/4	159	6-3/8	162	
<b>E</b>	11	279	14	357	16	406	18-7/8	479	17-7/8	454	15-1/4	387	
<b>F</b>	3-5/8	92	5-1/2	140	5-1/2	140	5-3/4	146	3-1/4	83	3-1/4	83	
<b>G</b>	3-5/8	92	5-1/2	140	5-1/2	140	5-3/4	146	4-5/8	117	6-3/8	162	
<b>Supply Air Opening</b>	Depth	17	432	17	432	17	432	17	432	21	533	21	533
	Width	13	330	16-1/2	419	16-1/2	419	19-7/8	505	19-7/8	505	19-7/8	505
<b>Return Air Opening</b>	Depth	20-3/4	527	20-3/4	527	20-3/4	527	20-3/4	527	24-3/4	629	24-3/4	629
	Width	12-1/2	318	16	406	16	406	19-3/8	492	19-3/8	492	19-3/8	492

## DIMENSIONS - UNIT - HORIZONTAL - INCHES (MM)

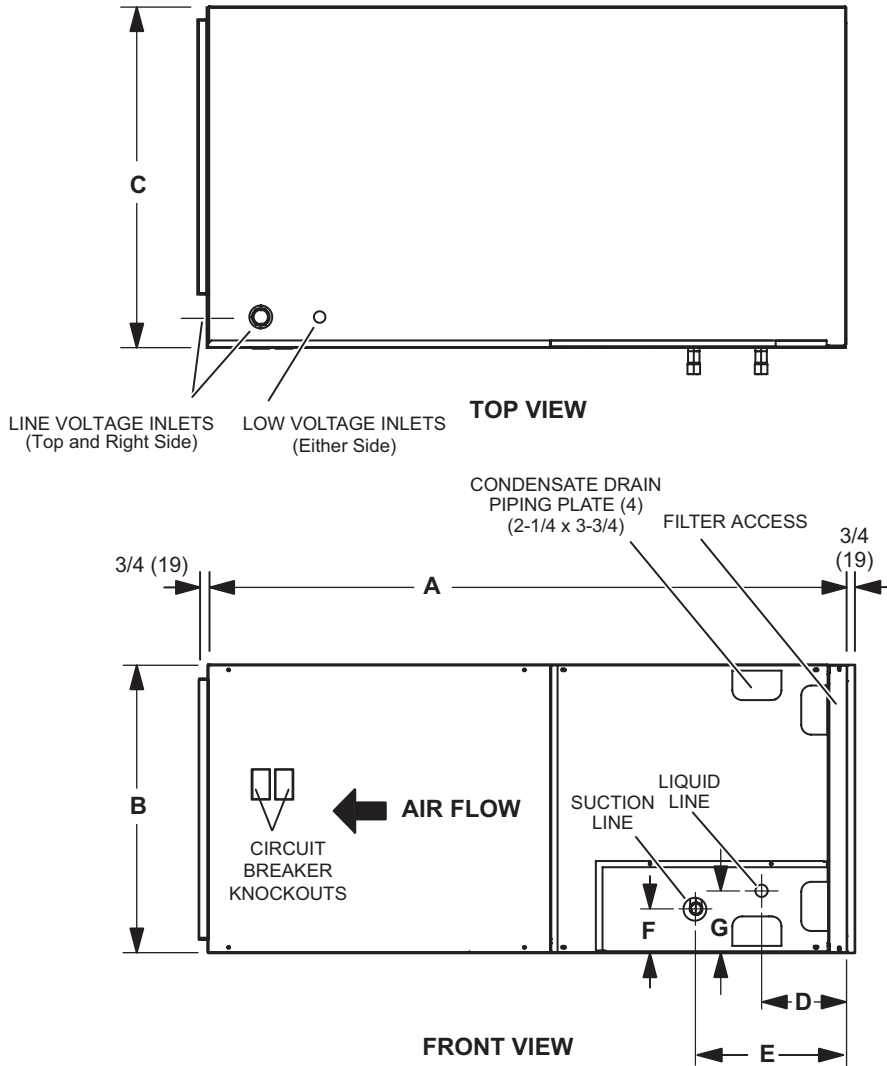

NOTE - Shipped for horizontal left-hand discharge.  
 May be field converted to horizontal right-hand air discharge by repositioning horizontal drain pan.

Dimension	018		024		030		036		042		048-060		
	in.	mm	in.	mm	in.	mm	in.	mm	in.	mm	in.	mm	
<b>A</b>	38	965	40-1/2	1029	43	1092	48	1219	48	1219	52-1/2	1334	
<b>B</b>	15	381	18-1/2	470	18-1/2	470	21-7/8	556	21-7/8	556	21-7/8	556	
<b>C</b>	22	559	22	559	22	559	22	559	26	660	26	660	
<b>D</b>	6	152	6	152	6	152	12-1/4	311	6-1/4	159	6-3/8	162	
<b>E</b>	11	279	14	357	16	406	18-7/8	479	17-7/8	454	15-1/4	387	
<b>F</b>	3-5/8	92	5-1/2	140	5-1/2	140	5-3/4	146	3-1/4	83	3-1/4	83	
<b>G</b>	3-5/8	92	5-1/2	140	5-1/2	140	5-3/4	146	4-5/8	117	6-3/8	162	
<b>Supply Air Opening</b>	Depth	17	432	17	432	17	432	17	432	21	533	21	533
	Height	13	330	16-1/2	419	16-1/2	419	19-7/8	505	19-7/8	505	19-7/8	505
<b>Return Air Opening</b>	Depth	20-3/4	527	20-3/4	527	20-3/4	527	20-3/4	527	24-3/4	629	24-3/4	629
	Height	12-1/2	318	16	406	16	406	19-3/8	492	19-3/8	492	19-3/8	492

**DIMENSIONS - ACCESSORIES - INCHES (MM)**

**SIDE RETURN UNIT STAND  
(Upflow Only)**

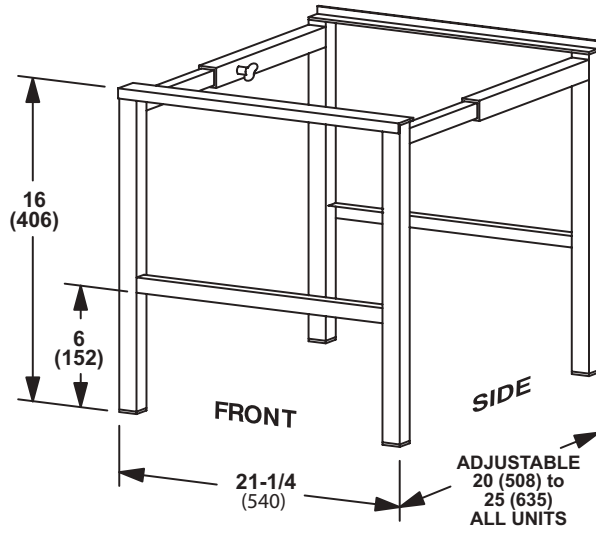

## REVISIONS

Sections	Description of Change
Electric Heat Data	Data updated for 5 kW electric heater. New catalog numbers for most electric heat models.



Visit us at [www.lennox.com](http://www.lennox.com)

For the latest technical information, [www.lennoxravenet.com](http://www.lennoxravenet.com)

Contact us at 1-800-4-LENNOX

NOTE - Due to Lennox' ongoing commitment to quality, Specifications, Ratings and Dimensions subject to change without notice and without incurring liability. Improper installation, adjustment, alteration, service or maintenance can cause property damage or personal injury. Installation and service must be performed by a qualified installer and servicing agency.

©2015 Lennox Industries, Inc.